

SOUTH JORDAN CITY GENERAL NOTES

(Updated 12-15-12)

1.1.0 South Jordan City General Notes

1. All work done or improvements installed within South Jordan City including but not limited to excavation, construction, roadwork and utilities shall conform to the South Jordan City Construction Standards and Specifications, City Municipal Code and the latest edition of the APWA Manual of Standard Specifications and Manual of Standard Plans, and any state or federal regulations and permit requirements of various governing bodies. The contractor is responsible to have a copy of these specifications and to know and conform to the appropriate codes, regulations, drawings, standards and specifications.

2. The existence and location of any overhead or underground utility lines, pipes, or structures shown on these plans are obtained by a research of the available records. Existing utilities are located on plans only for the convenience of the Contractor. The contractor shall bear full responsibility for the protection of utilities and the engineer bears no responsibility for utilities not shown on the plans or not in the location shown on the plans. This includes all service laterals of any kind. The Contractor shall, at his own expense, locate all underground and overhead interferences, which may affect his operation during construction and shall take all necessary precautions to avoid damage to same. The Contractor shall use extreme caution when working near overhead utilities so as to safely protect all personnel and equipment, and shall be responsible for all cost and liability in connection therewith.

3. The Contractor shall take all precautionary measures necessary to protect existing utility lines, structures, survey monuments and street improvements which are to remain in place, from damage, and all such improvements or structures damaged by the Contractor's operations shall be repaired or replaced satisfactory to the City Engineer and owning utility company at the expense of the Contractor.

4. All construction shall be as shown on these plans, any revisions shall have the prior written approval of the City Engineer.

5. Permits are required for any work in the public way. The Contractor shall secure all permits and inspections required for this construction.

6. Curb, gutter, and sidewalk, found to be unacceptable per City Standards and APWA shall be removed and replaced.

7. Contractor shall provide all necessary horizontal and vertical transitions between new construction and existing surfaces to provide for proper drainage and for ingress and egress to new construction. The extent of transitions to be as shown on plans.

8. Any survey monuments disturbed shall be replaced and adjusted per Salt Lake County Surveyors requirements.

9. All privacy walls, new or existing, are only shown on civil plans for the purpose of reviewing grading relationships; flood control and sight distance at intersections. All walls shall have a minimum 2 ft x 2 ft x 30 inch deep spot footings. Bottom of all footings on all walls shall be a minimum of 30 inches below finished grade. Walls greater than 6 feet require a separate permit and inspection by the Building Department.

10. All construction materials per APWA must be submitted and approved by the City Engineer prior to the placement of asphalt within City Right of Way.

11. Request for inspection by the City of South Jordan engineering dept. shall be made by the contractor at least 48 hours before the inspection services will be required.

12. Work in public way, once begun, shall be prosecuted to completion without delay as to provide minimum inconvenience to adjacent property owners and to the traveling public.

13. The contractor shall take all necessary and proper precautions to protect adjacent properties from any and all damage that may occur from storm water runoff and/or deposition of debris resulting from any and all work in connection with construction.

14. Power poles and/or other existing facilities not in proper location based on proposed improvements shown hereon will be relocated at no expense to the City of South Jordan. Power lines and all other aerial utilities are to be buried and poles removed as determined by the City Engineer.

15. Curb and gutter with a grade of less than four-tenths of one percent shall be constructed by forming. Each joint shall be checked for a grade prior to construction and water tested as soon as possible after construction.

16. Contractor to follow Salt Lake County Noise Ordinance Standards.

17. Contractors are responsible for all OSHA requirements on the project site.

18. Trench backfill material under pavements or surface improvements shall be clean, non-clumping, granular and flowable (2" minus A-4 soils are acceptable according to AASHTO 145 soil Classification System). Lime treated flowable fills, if approved, shall have a 28-day strength of 65 PSI.

19. A UPDES (Utah Pollutant Discharge Elimination System) permit is required for all construction activities as per state law as well as providing a Storm Water Pollution Prevention Plan to the City.

20. Developer is responsible for locating and repairing all underground streetlight wires, water lines, storm drain lines and irrigation lines until 90% of the bond has been released.

21. All City maintained utilities including; waterline, fire hydrants, streetlight wiring, and storm drain must be in public right of way or in recorded easements.

22. Contractor shall work South Jordan City regular working hours of Monday through Friday. If Contractor permits overtime work or work on a Saturday, Sunday or any legal holiday, Contractor shall receive prior approval by City Engineer. Contractor shall obtain all permits and pay Overtime Inspection Fee's to The City of South Jordan on the Thursday prior to the Saturday, Sunday or legal holiday requested.

23. Prior to 90% bond release, a legible as-built drawing must be submitted to the City of South Jordan stamped and signed by a professional engineer. As-builts must show all changes and actual field locations of storm drainage, waterlines, irrigation, street lighting, and power. As-builts will be held to the same standard as approved design drawings, no "redlined plans" allowed. In the absence of changes, copies of the approved drawings will be required stating "installed as per drawings". As-built drawings for new developments shall be submitted to the City in the following formats and quantities prior to the 90% bond release: 1 .dxf copy, 1 .pdf copy.

24. Filter fabric wrapped around an inlet grate is not an acceptable inlet sediment barrier. See Chapter 9 of South Jordan City Construction Standards and Specifications for details of approved storm water BMPs.

25. Asphalt paving between October 15 and April 15 is not allowed without a written exception from the Engineering Department.

1.2 City of South Jordan Traffic Notes

1. When a designated "Safe Route To School" is encroached upon by a construction work zone the safe route shall be maintained in a manner acceptable to South Jordan City and the Jordan School District.

2. If the improvements necessitate the obliteration, temporary obstruction, temporary removal or relocation of any existing traffic pavement marking, such pavement marking shall be restored or replaced with like materials to the satisfaction of the City Engineer, Public Works

Director or designee.

3. The street Sign Contractor shall obtain street names and block numbering from the Planning Department prior to construction.

4. The Contractor shall be responsible for providing and installing all permanent signs shown on the plans. Street name signs shall conform in their entirety to current City Standards. All other signs shall be standard size unless otherwise specified on the plans. All sign posts shall be installed in accordance with the current City Standards.

5. All permanent traffic control devices called for hereon shall be in place and in final position prior to allowing any public traffic onto the portions of the road(s) being improved hereunder, regardless of the status of completion of paving or other off-site improvements called for per approved construction drawings unless approved by the City Engineer.

6. The Contractor shall be responsible for notifying Utah Transit Authority (UTA) if the construction interrupts or relocates a bus stop or has an adverse effect on bus service on that street to arrange for temporary relocation of stop.

7. Before any work is started in the right-of-way, the contractor shall install all advance warning signs for the construction zone. The contractor shall install temporary stop signs at all new street encroachments into existing public streets. All construction signing, barricading, and traffic delineation shall conform to the Manual of Uniform Traffic Control Devices (MUTCD) per the current edition adopted by UDOT and be approved by the City of South Jordan before construction begins.

8. All signs larger than 36" X 36" or 1296 square inches per sign pole shall be mounted on a Slip Base system per UDOT standard drawing SN 10B (detail drawing attached to standard drawings) with a "Z" bar backing. Signs of this size are not allowed to be mounted on a yielding pole.

9. Sign components such as sheeting, EC film, inks, letters and borders are all required to be from the same manufacturer. Only EC film may be used to achieve color. Vinyl EC film is not accepted.

10. All new roundabouts, crosswalks, stop bars and legends shall be installed with 90mil preformed thermo plastic.

11. Paving asphalt binder grade shall be PG 64-22 unless otherwise approved by the City Engineer.

1.3 City of South Jordan Street Light Notes

1. All work shall be installed in accordance with the most current South Jordan City Standards and N.E.C. (National Electric Code). A street light plan showing wiring location, wiring type, voltage, power source location, conduit size and location shall be submitted to the City of South Jordan and be approved prior to construction. No deviation of streetlight, pull boxes, conduits, etc. locations shall be permitted without prior WRITTEN APPROVAL from the City Engineer or his/her representative.

2. Location of the Street light pole. a. Shall not be installed within 5 feet of a fire hydrant. The location shall be such that it does not hinder the operation of the fire hydrant and water line operation valves. b. Shall be a minimum of 5 feet from any tree, unless written approval is received from the City Engineer. Branches may need to be pruned as determined by the Engineering Inspector in the field at the time of installation. c. Shall not be installed within 5 feet from the edge of any driveway.

3. Anti-seize lubricant shall be used on all cover bolts and ground box bolts.

4. All existing street lighting shall remain operational during construction.

5. Any structure such as block walls, chain link fences, retaining walls, etc. shall leave a minimum of eighteen (18) inches to the face of the street light pole on all sides.

6. All service point(s) shall be coordinated with Rocky Mountain Power and whenever possible be located near the center of the circuit. Service point(s) shall be shown on the plans with a schematic from Rocky Mountain Power. Pole locations as shown on the approved plans may be adjusted in the field by the Engineering Inspector at time of installation at no additional cost to the City.

7. It shall be required that in the absence of an existing workable circuit to attach to, that all installations shall require a new service for operation of the circuits in this case developer and or his engineer shall contact Rocky Mountain Power.

8. Wherever there is an overhead utility that may conflict with the installation of the street light circuits and/or streetlight poles, those conflicts must be resolved between the developer and the utilities involved before the street light bases are constructed at no expense to the City of South Jordan or Rocky Mountain Power. The resolution must be approved by the City of South Jordan and Rocky Mountain Power.

9. The contractor shall furnish a complete service to the transformers and control systems if required on the plans and/or is deemed necessary by Rocky Mountain Power and/or South Jordan City.

10. A street light plan showing wiring location, wiring type, voltage, power source location, conduit size and location shall be submitted to the City of South Jordan and be approved prior to construction.

11. The contractor shall be required to perform a 10 day burn test of the street lights after they are connected and energized by Rocky Mountain Power. This test shall be coordinated and witnessed by a South Jordan Engineering Inspector.

12. Each streetlight shall have its own photo cell independent of a master control.

1.4 City of South Jordan Grading Notes

1. In the event that any unforeseen conditions not covered by these notes are encountered during grading operations, the Owner and City Engineer shall be immediately notified for direction.

2. It shall be the responsibility of the Contractor to perform all necessary cuts and fills within the limits of this project and the related off-site work, so as to generate the desired subgrade, finish grades and slopes shown.

3. Contractor shall take full responsibility for all excavation. Adequate shoring shall be designed and provided by the Contractor to prevent undermining of any adjacent features or facilities and/or caving of the excavation.

4. The Contractor is warned that an earthwork balance was not necessarily the intent of this project. Any additional material required or leftover material following earthwork operations becomes the responsibility of the Contractor.

5. Contractor shall grade to the lines and elevations shown on the plans within the following horizontal and vertical tolerances and degrees of compaction, in the areas indicated: Horizontal Vertical Compaction a. Pavement Area Subgrade 0.1'+ +0.0.' to -0.1' See soils Report b. Engineered Fill 0.5'+ +0.1.' to -0.1' See Soils Report Compaction Testing will be performed by the developer or his representative.

6. All cut and fill slopes shall be protected until effective erosion control has been established.

7. The use of potable water without a special permit for building or construction purposes including consolidation of backfill or dust control is prohibited. The Contractor shall obtain all necessary permits for construction water from the Public Works Department.

8. The Contractor shall maintain the streets, sidewalks and all other public right-of-way in a clean, safe and usable condition. All spills of soil, rock or construction debris shall be promptly removed from the publicly owned property during construction and upon completion of the project. All adjacent property, private or public shall be maintained in a clean, safe and usable condition.

9. In the event that any temporary construction items is required that is not shown on these drawings, the Developer agrees to provide and install such item at his own expense and at the direction of the City Engineer. Temporary construction includes ditches, berms, road signs and barricades, etc.

10. All grading work shall conform to the soils report as prepared by the Soils Engineer and approved by the City Engineer, and as shown on these plans.

1.5 City of South Jordan Fire Department Notes

1. On any new home or building installation, accessible fire hydrants shall be installed before combustible construction commences and said fire hydrants shall be in good working order with an adequate water supply.

2. Contractor shall call the Public Works Department and Engineering Inspector for underground inspection, pressure and flush verification of all fire hydrants and fire lines before back filling.

3. Painting of the curbs and hydrant and any work necessary for protection of hydrants from physical damage shall be approved before being constructed.

4. A flow test must be witnessed by the Fire Department prior to occupancy for verification of required on-site water supply.

5. All on-site fire main materials must be U.L. listed and A.W.W.A. approved.

6. The turning radius for any fire apparatus access road and/or fire lane, public or private, shall be not less than forty-five feet (45') outside radius and twenty-two feet (22') inside radius and shall be paved.

7. A fire apparatus road shall be required when any portion of an exterior wall of the first story is located more than one-hundred fifty feet (150') from Fire Department vehicle access roads and/or fire lanes, public or private, in excess of onehundred fifty feet (150') in length shall be provided with an approved turn around area.

8. Access roads shall be marked by placing approved signs at the start of the designated fire lane, one sign at the end of the fire lane and width signs at intervals of one-hundred feet (100') along all designated fire lanes. Signs to be placed on both sides of an access roadway if needed to prevent parking on either side. Signs shall be installed at least 5', measured from the bottom edge of the sign to the near edge of pavement. Where parking or pedestrian movements occur, the clearance to the bottom of the sign shall be at least 7'. The curb along or on the pavement or cement if curb is not present, shall be painted with red weather resistant paint in addition to the signs.

9. Electrically controlled access gates shall be provided with an approved emergency vehicle detector/receiver system. Said system shall be installed in accordance with the South Jordan City F.D. Approval. Gates are only allowed with prior Approval.

10. All underground fire lines that service automatic fire sprinkler systems shall be no smaller than six (6) inches in diameter. All fire lines material shall be Ductile Iron. (Ductile Iron from the PIV to the building shall be permitted or Ductile Iron from the main water line to the WV).

11. Post Indicator Valves (PIV) shall be between 6 and 40 feet from buildings not exceeding three stories or equivalent in height and between 30 and 40 feet on buildings in excess of three or more stories in height or equivalent.

12. Roads and accesses shall be designed and maintained to support the imposed loads of fire apparatus. Surface shall be paved before the application of combustible material.

1.6 South Jordan City Water Notes

1. The following South Jordan City Water Notes are intended for general water standards only and are not all inclusive. The City has included the Culinary Water Design and Construction Standards within the City Construction Standards and Specifications.

2. No work shall begin until the water plans have been released for construction by the Engineering Department. Following water plan approval, forty-eight (48) hour notice shall be given to the Engineering Inspector and the Public Works Department (253- 5230) prior to the start of construction. Notice must be given by 2:00 P.M. the business day prior to an inspection.

3. All work within South Jordan City shall conform to South Jordan City Standards and Specifications, AWWA and APWA.

4. For Residential Developments - The developer shall purchase and install meter boxes and setters according to City Standards on newly developed lots and real property at the time of water main installation. Water meters will be supplied and installed by South Jordan Public Works Department (at developer's expense). The developer shall also provide the site address, lot number, meter size and pay meter fees prior to building permit approval.

5. For Commercial and Condominium Developments - The developer shall purchase and install water meters, meter boxes and setters according to City Standards. Water meters will be supplied and installed by South Jordan Public Works Department (at developer's expense) and installed by developer.

6. All water facilities shall be filled, disinfected, pressure tested, flushed, filled and an acceptable water sample obtained prior to commissioning the new water line to the South Jordan City Culinary Water Distribution System.

7. South Jordan Public Works Department must approve water shut down which may require evening and weekend shut down as deemed necessary, requiring the contractor to be billed for overtime. 48 hour notice is required.

8. Water stub-out installations will not be construed as a commitment for water service.

9. Conditional Approval of Valved Outlet (6" and Larger): In the event the water plans show one or more valved outlets extending out of paved areas, installations of these outlets is acceptable, however, if the outlets are incorrectly located or not used for any reason when the property is developed, the developer shall abandon the outlets at the connection to the active main in accordance with the city standards and at the developer's expense.

10. All lines to be pressure tested according to South Jordan City and AWWA standards and chlorinated prior to use and final acceptance.

11. All fittings to be coated with poly fm grease and wrapped with 8-mil thick polyethylene.

12. No other utility lines may be placed in the same trench with water line unless approved by the City Engineer.

13. Any conflict with existing utilities shall be immediately called to the attention of the City Engineer or designee.

14. All water vaults will be constructed per City of South Jordan standard drawings and specifications. No vaults are allowed in traffic areas without prior approval of the City.

15. Landscaping and irrigation adjacent to vaults shall drain away from vaults.

16. Once the waterline has been tested, approved and city water is flowing through the pipe, only City personnel are authorized to shut down and charge the waterline.

17. Megalug following ring or an approved equivalent shall be used on all fittings.

18. APWA plan 562, City requires stainless steel tie-down restraints with turnbuckles only. 5/8" rebar is not acceptable. Megalug followers required on all fittings and all dimensions of thrust blocking still apply. Thrust blocks may be eliminated if horizontal tie down restraints have been pre-engineered and receive prior City approval.

(Updated 3/24/10)

All construction of public improvements shall conform to the most current edition of the APWA Manual of Standard Specifications, Manual Standard Plans and the South Jordan City Construction Standards and Specifications. The contractor is responsible to have a copy of these specifications. The order of precedence in case of conflict shall be (1) South Jordan City Construction Standards and Specifications (2) APWA (3) The approved Construction drawings.

Any changes from the final approved set of plans must be revised by the design engineer with stamp and signature and submitted to the South Jordan City Engineering Department for approval.

1. CULINARY WATER

A. Pipe type: The Contractor must use Blue C-900 PVC -DR18 with tracer wire and caution tape (all wire connections need a moisture resistant nut). All trench backfill needs to be between A-1-a and A-4 soil under the AASHTO Soil Classification System, and pass compaction test's of at least 96% in R.O.W. The pipe needs to be bedded with sand from 6" under the pipe to 18" above top of pipe.

B. Joints: Cast iron mechanical joints. Megalug following ring or an approved equivalent shall be used on all fittings. Coat nuts and bolts with poly F.M. grease and wrap with 8-millimeter thick poly. Any MJ joints must have the bevel removed from the spicket end before being installed into MJ fitting.

C. Fire Hydrants: Mueller Centurion A-423 or Clow Medallion hydrants only. The Buryline must be even with top back of curb (TBC). Coat and wrap with poly and grease bolts, do the same to the auxiliary valve. An 18" spool must be placed between hydrant and auxiliary valve. Snake the pipe using mj. X fl. tee to place the fire hydrant in the center of the parkstrip. Turn the hydrant to face the street and plumb in all directions to make sure it is level. Pour large thrust block to insure stability. Make sure thrust block is poured squarely against native soil, i.e. do not make it bullet shaped or angled. Hydrant base and auxiliary valve box must be placed in 4'x 5' by 6" thick concrete pad, level with the sidewalk. Place expansion material between TBC and the sidewalk. All hydrants must have a Gravel Drain to allow proper drainage. Any hydrants installed in a P.U.D. must be mega lugged.

D. Blow Off: All water line blow offs will require 2 water valve boxes, one for water valve and one for blow off riser. Riser shall be threaded, with a thread protector cap and placed 6" below finish grade.

E. Chlorine Test: To be checked by the South Jordan City Water Department. Must notify water department @ (253-5230) and set up a work order 48 hours prior to filling line. Chlorine flushing discharge for testing needs to be regulated by diffuser or City approved equivalent.

F. Bacteria Test: Bacteria test will be done by South Jordan City Water Department after the chlorine tests have passed and Contractor has flushed all lines.

G. Pressure Test: Waterline must be pressure tested prior to tapping services at 200 pounds per square inch (P.S.I.) and must be maintained for 2 hours minimum and witnessed by the South Jordan City Water Department.

H. Service Boxes: Service Boxes shall be HDPE (preferably white). Use INSTA-TITE Mueller parts. -18" diameter box for 3/4" IPS (Iron Pipe Size) polyethylene (PE) blue pipe service. -24" diameter box for 1" IPS (Iron Pipe Size) polyethylene (PE) blue pipe service. -36" diameter box for 1-1/2" or 2" CTS (Copper Tube Size) polyethylene (PE) blue pipe service. -APWA approved vault is needed for any water meters over 2". All Polyethylene must be beveled with a manufacturer's beveling tool. Make sure corp stop is turned on. Laterals must be compacted to 1' behind sidewalk.

I. Mainline: Mainline must be buried to a minimum of 48" below finish grade; this will keep the pipe from freezing. Maximum of 5-foot depth for maintenance accessibility.

J. Brass Marker: To be placed on the front curb, marked with a "W" for water to be stamped and installed by the contractor.

K. Compaction Tests: All laterals - water, sewer, storm drain etc. will be tested for compaction by the developer and the results given to the Engineering Inspector with a minimum 96% modified proctor.

L. Valves: All valves must be accessible with a standard 6' valve key, regardless of design or design change, and need to be Mueller or Clow valves or approved equal (approval must be granted in writing before constructing).

M. Water Testing Fee: All flushing of culinary water such as but not limited to new development water system testing shall be assessed a fee and the cost of water used.

N. Commercial Water Meters: If the developer/contractor requests a change in meter size after the construction drawings have been approved by the City, the request must be submitted by licensed design engineer with stamp and signature. The culinary water main tap must be same size as meter size. A new tap off the main is required if tap size is not same as meter size.

O. Manhole lids: Water vault manhole lid specifications: ASTM A 48-93, Class 35B Cast iron construction, machined flat bearing surface, removable lid with pick holes, H=20 highway load rating; lid molded with South Jordan City name and logo imprinted on lid. Provide Model A-1180 manufactured by D&L Foundry & Supply, or acceptable equal.

2. SECONDARY IRRIGATION

A. Pipe type: Purple Pipe, C-900 PVC, DR-18 with tracer wire and caution tape (all wire connections need a moisture resistant nut).

B. Mainline: Must be buried to a minimum of 36" below finish grade. Compaction of 96% using a modified proctor is required. The pipe needs to be bedded in sand from 6" under the pipe to 18" above top of pipe.

C. Location: Install at front property line in the parkstrip.

D. Blow Off: All water line blow offs will require 2 water valve boxes, one for water valve and one for blow off riser. Riser shall be threaded, with a thread protector cap and placed 6" below finish grade.

E. Air-Vac: Placed in standard 18 inch meter box with ball valve below air-vac.

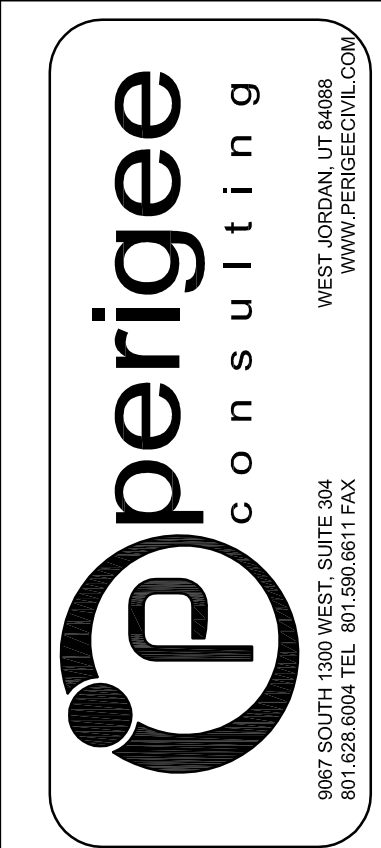

Table with 2 columns: CITY ENGINEER, DATE

Table with 2 columns: CITY ENGINEER, DATE

Table with 2 columns: CITY ENGINEER, DATE

Table with 2 columns: CITY ENGINEER, DATE

Table with 2 columns: CITY ENGINEER, DATE

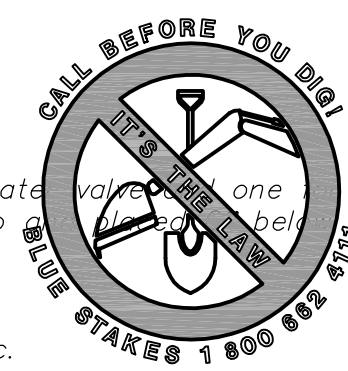

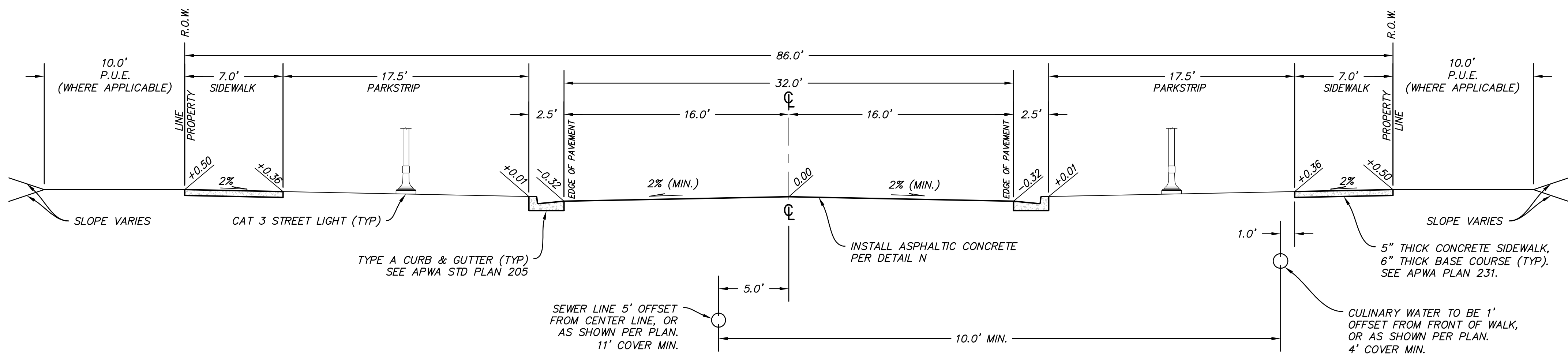

**CONNECTOR - 86' ROW
CROSSWATER ROAD**

(H)
VAR SCALE: 1" = 5'

- ROADWAY SECTION NOTES:**
1. ALL ROADS HAVE CUT AND FILL SLOPES OF 3:1 UNLESS NOTED ON PLANS. ALL FILLS MUST BE APPROVED BY THE CITY ENGINEER PRIOR TO PLACEMENT.
 2. CONTRACTOR TO COMPLY WITH THE RECOMMENDATIONS PROVIDED BY THE VILLAGE 3 AND PLAT 9 GEOTECHNICAL REPORT (PROJECT #3-817-004657 & 15-817-05393) FOR THIS PROJECT REGARDING SITE PREPARATION, GRADING, COMPACTION ETC.
 3. ALL STREET LIGHTS SHALL BE INSTALLED WITH LIGHT CONCRETE PEDESTAL AS PER SOUTH JORDAN CITY STANDARD DETAIL, "STREET LIGHT DETAIL, LIGHT PEDESTAL DETAIL, CATEGORY 1, 2, 3 & 4."
 4. COMPACT PER APWA SECTION 02324 TO A MODIFIED PROCTOR DENSITY OF 96% OR GREATER.
 5. SIDEWALK AND PARK STRIP LOCATIONS VARY. SEE STREET PLANS FOR SIDEWALK LOCATIONS.
 6. COLD WEATHER PAVING APPROVAL WILL BE REQUIRED BY SJC AFTER OCTOBER 15
 7. PAVEMENT SECTIONS BASED ON DAYBREAK VILLAGE 3 AND PLAT 9 GEOTECHNICAL REPORT DATED ON JULY 20, 2007. PROJECT NO. 3-3817-004657 PHASE 60 AND SUPPLEMENTARY LABORATORY TESTING PROJECT NO. 15-817-05393

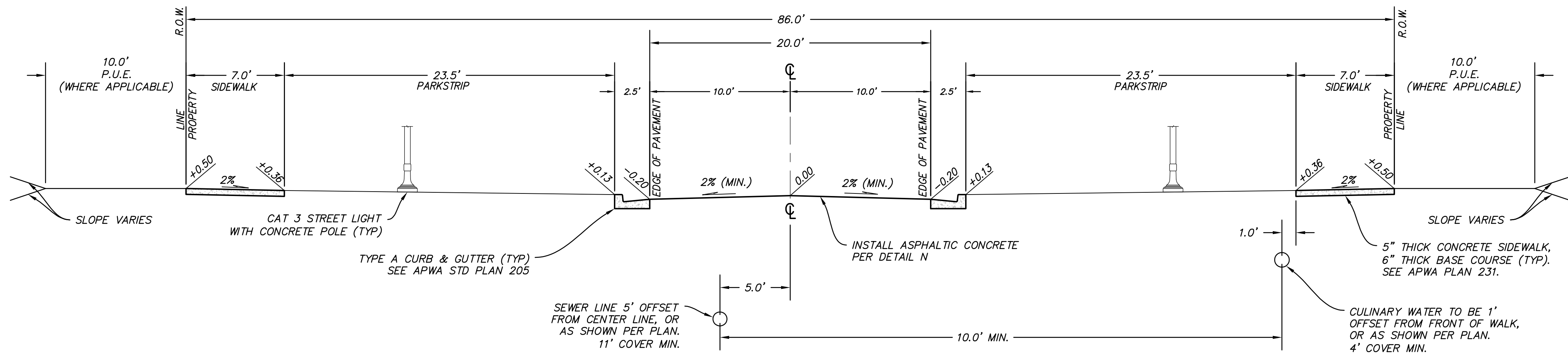

**CONNECTOR BUMP OUT - 86' ROW
CROSSWATER ROAD**

(G)
VAR SCALE: 1" = 5'

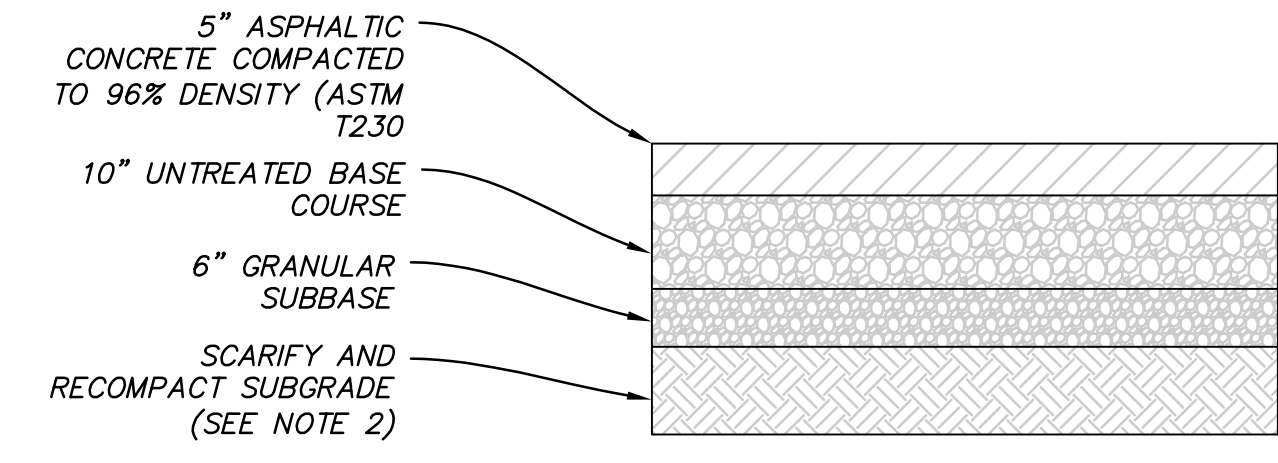

PAVEMENT SECTION (COLLECTOR & CONNECTOR)

(N)
VAR SCALE: N.T.S.

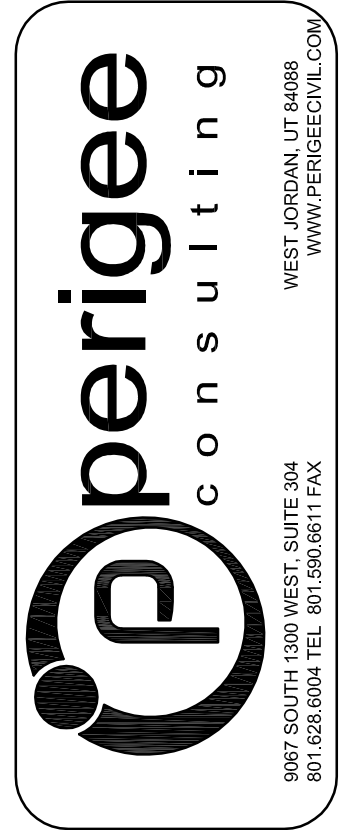

SOUTH JORDAN CITY

CITY ENGINEER DATE

NO.	DATE	DESCRIPTION	MARK

DESIGNED BY: JTA	DATE: SEPT. 2015	REV:
DRAWN BY: SKS	CITY OF: XXX	SUBMITTANCE:
SUBMITTED BY:	CONTRACT NO: 00387	FILE NAME:
FILE NAME: N:\00182_Daybreak\0004\PAV\07_0105	PILOT DATE: 6/10/2015 3:20:34 PM	SIZE: VARIED

**DAYBREAK
PLAT 101**
TYPICAL ROADWAY SECTIONS
TYPICAL ROAD SECTIONS

SHEET NUMBER
07
OF 24 SHEETS
DRAWING NAME
GN05



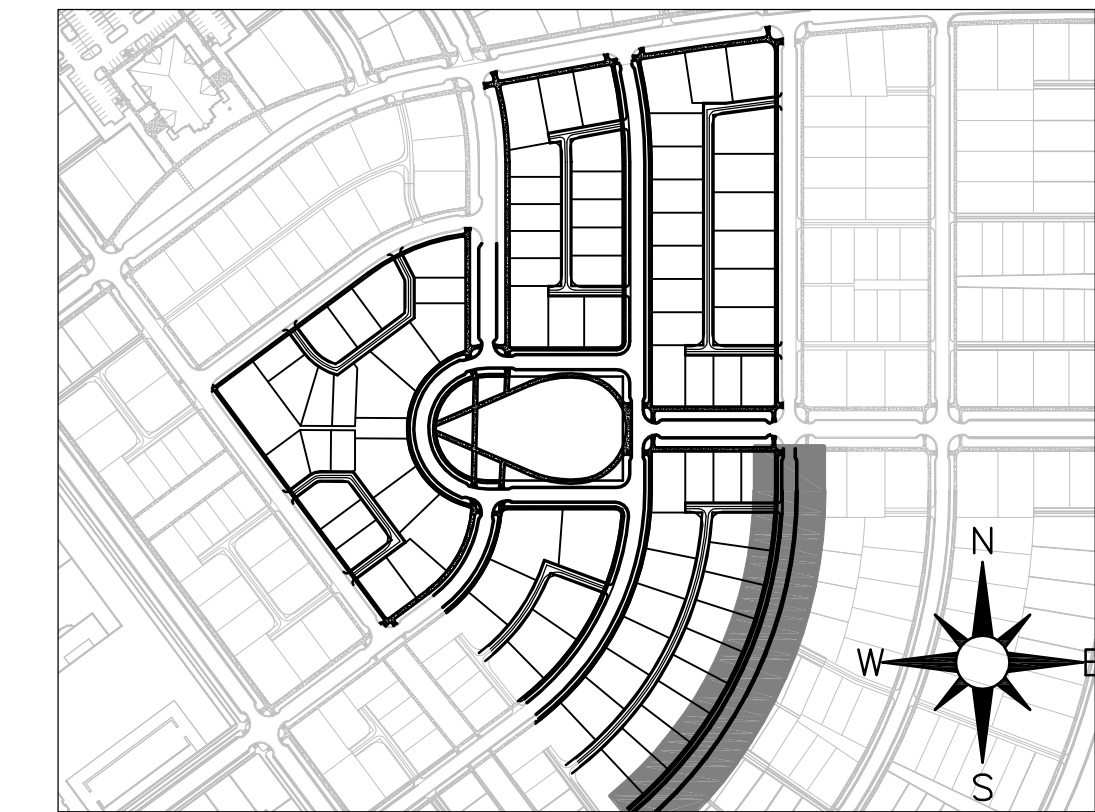
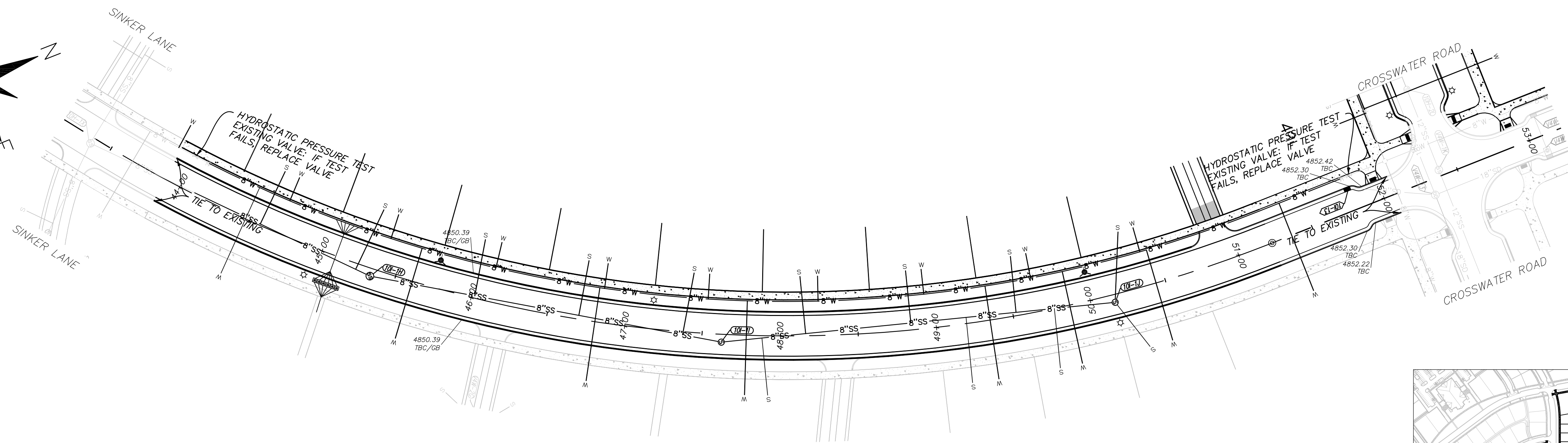
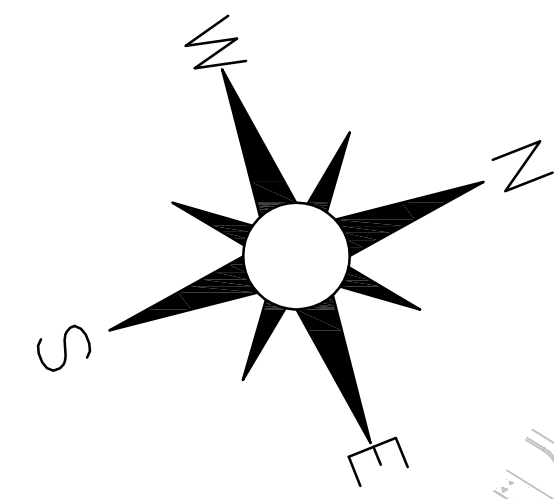

LAKE TERRACE AVENUE
STA: 43+00 TO 53+00

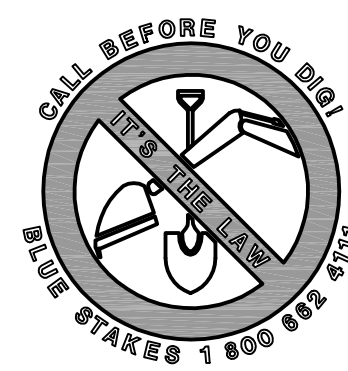
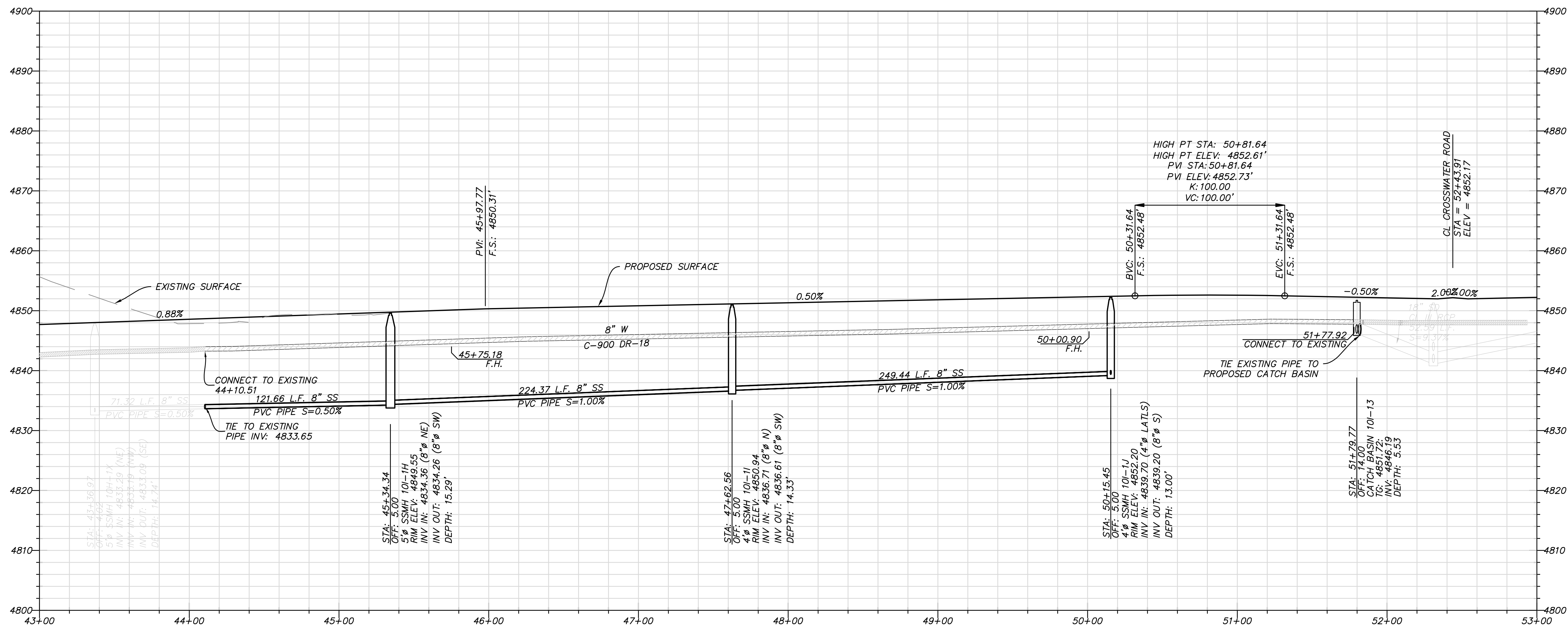

NO.	DATE	DESCRIPTION	BY	CHK

DESIGNED BY: JTA	DATE: SEPT. 2015	REV:
DRAWN BY: SKS	CITY BY: XXX	SUBMITTAL NO: 00387
FILE NAME: N:\00182_Daybreak\00387\PP05\PP05	PROJECT DATE: 8/10/2015 3:28:37 PM	SIZE: VARIED

DAYBREAK PLAT 101
PLAN AND PROFILE - LAKE TERRACE AVENUE

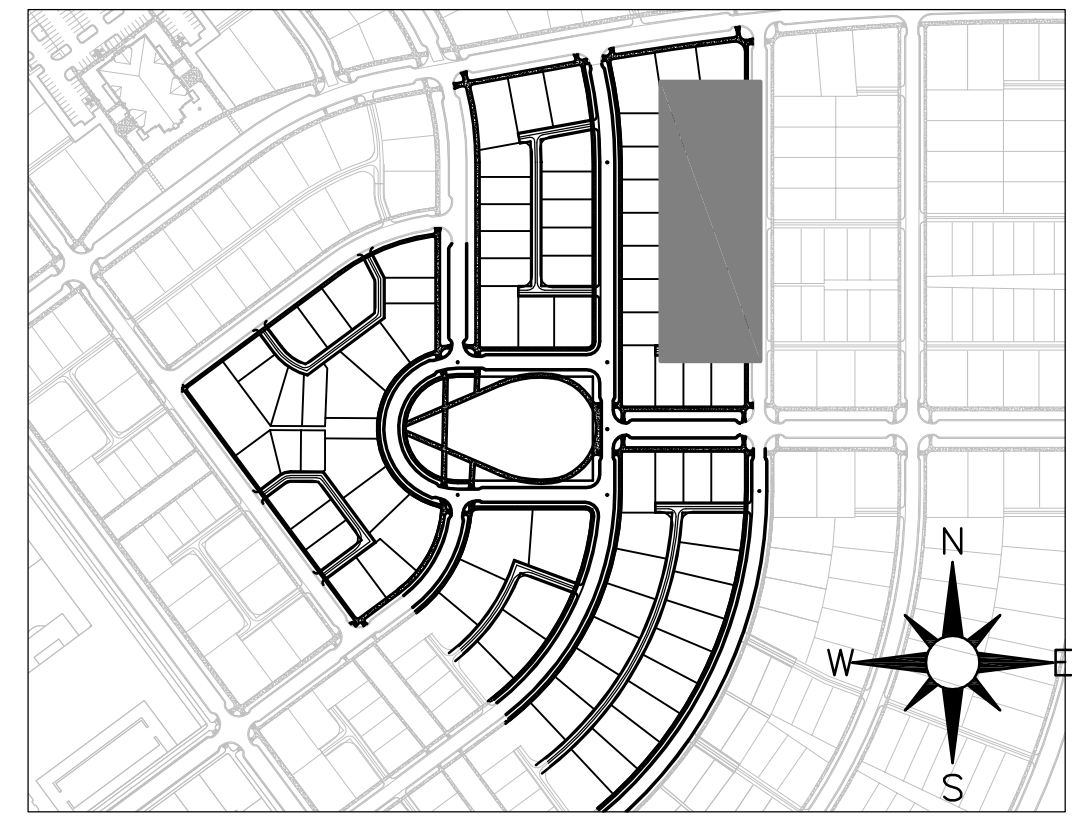
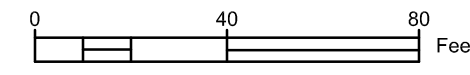
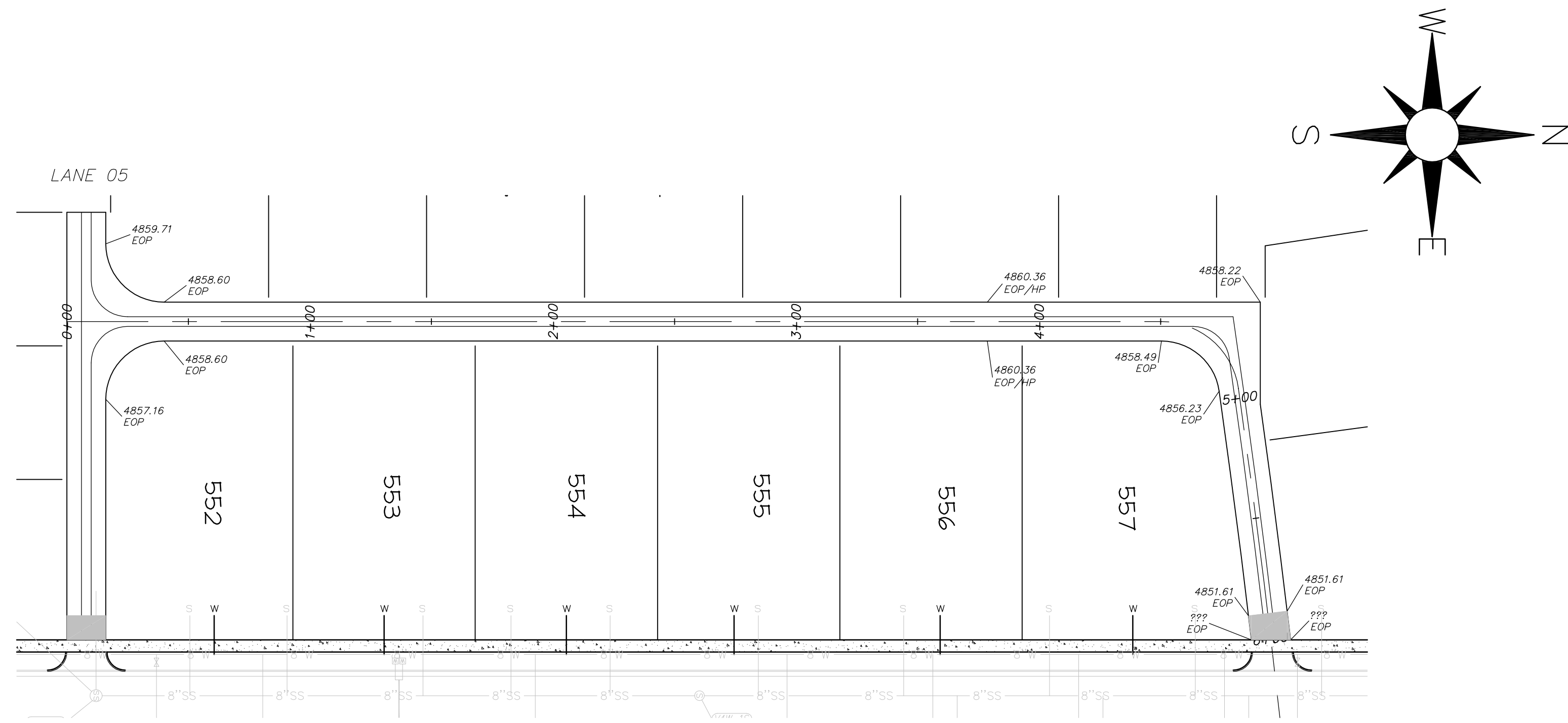

KEY MAP

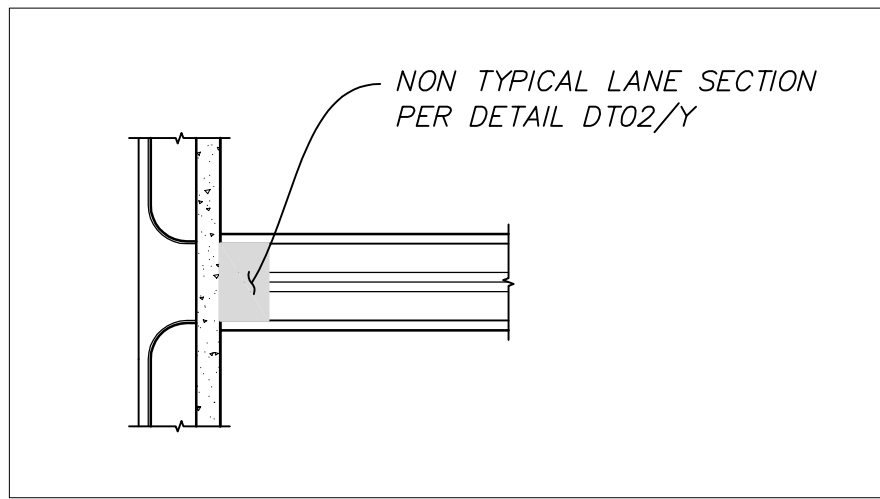

LANE 04
STA: 0+00 TO 6+50

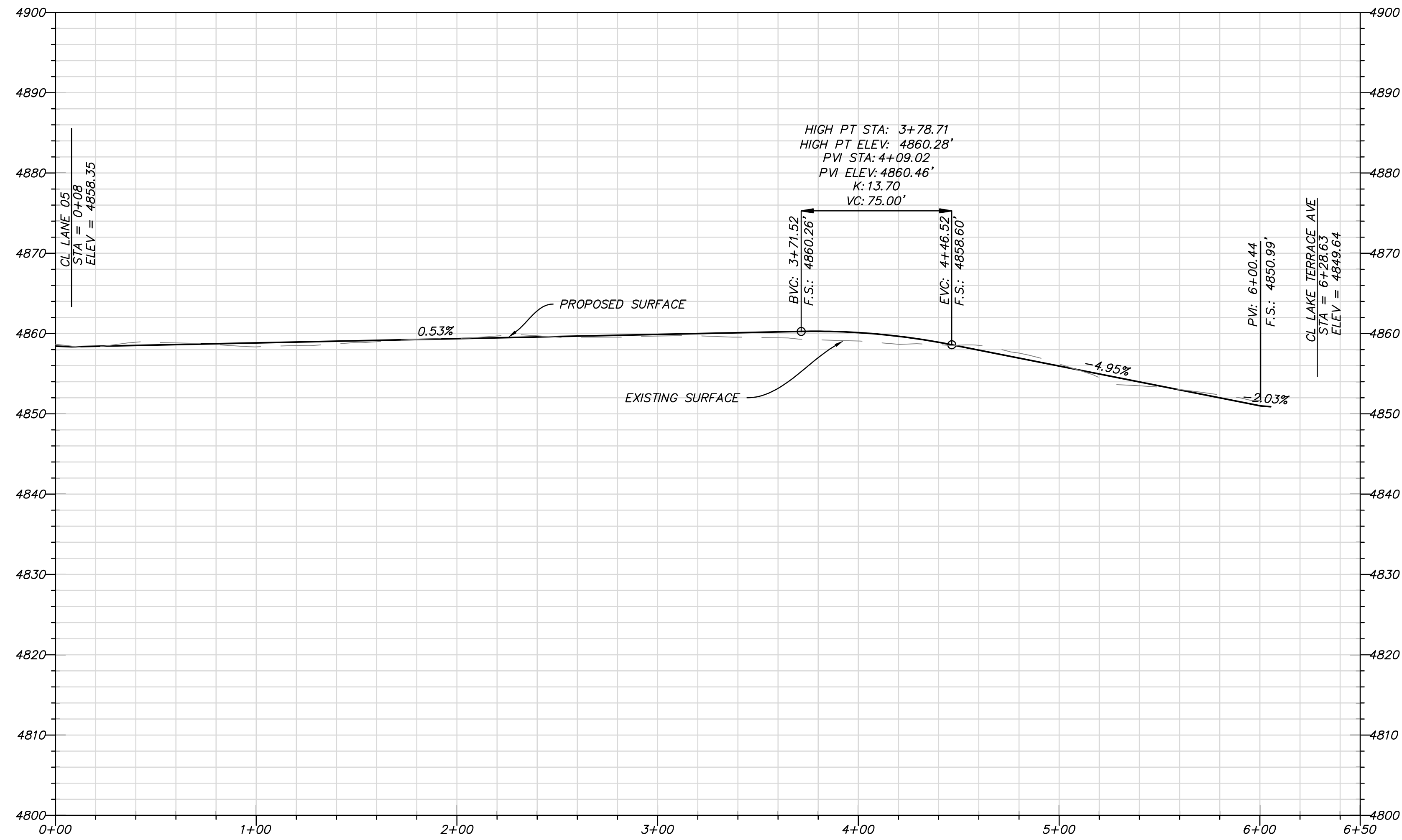

SOUTH JORDAN CITY

CITY ENGINEER DATE

REV.	DATE	DESCRIPTION	MARK	DATE	APP.

DESIGNED BY: JTA	DATE: SEPT. 2015	REV.
DRAWN BY: SKS	CITY: XXX	SOLICITATION:
SUBMITTED BY:	CONTRACT NO: 00387	
FILE NAME: N:\00182_Daybreak\00387\PLAN\18_PP08	PROJECT DATE: 8/10/2015 3:32:28 PM	
SIZE: A3	PLOTTED BY:	
VERSION:		

DAYBREAK
PLAT 101

PLAN AND PROFILE - LANE 04

SHEET NUMBER
18
OF 24 SHEETS
DRAWING NAME
PP08



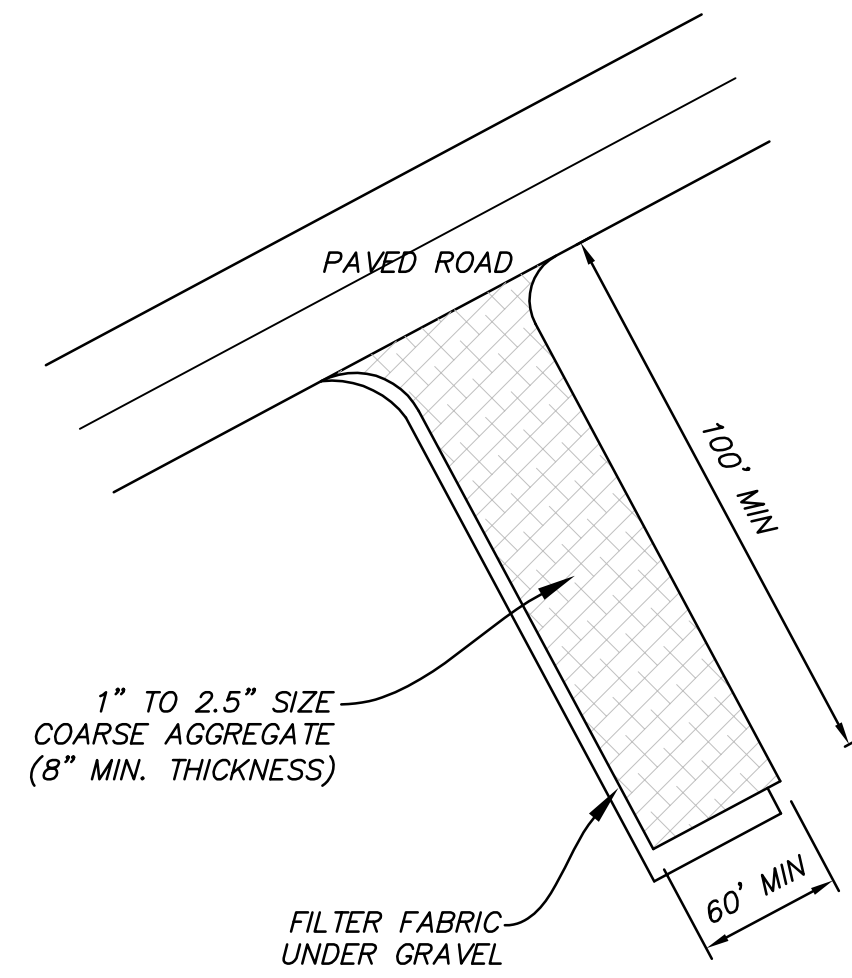

MM VAR STABILIZED CONSTRUCTION ENTRANCE
NOT TO SCALE

- NOTES:**
1. ALL MATERIAL TO MEET FILTREXX SPECIFICATIONS.
 2. THE CONTRACTOR SHALL MAINTAIN THE COMPOST FILTER BERM IN A FUNCTIONAL CONDITION AT ALL TIMES AND IT SHALL BE ROUTINELY INSPECTED.
 3. BERM WILL BE REGULARLY INSPECTED AND REPAIRED AS NECESSARY.
 4. THE CONTRACTOR SHALL REMOVE SEDIMENT COLLECTED AT THE BASE OF THE BERM WHEN THEY REACH 1/3 OF THE EXPOSED HEIGHT OF THE BERM, OR AS DIRECTED BY THE ENGINEER.
 5. THE COMPOST FILTER BERM WILL BE DISPERSED ON SITE WHEN NO LONGER REQUIRED, AS DETERMINED BY THE ENGINEER.

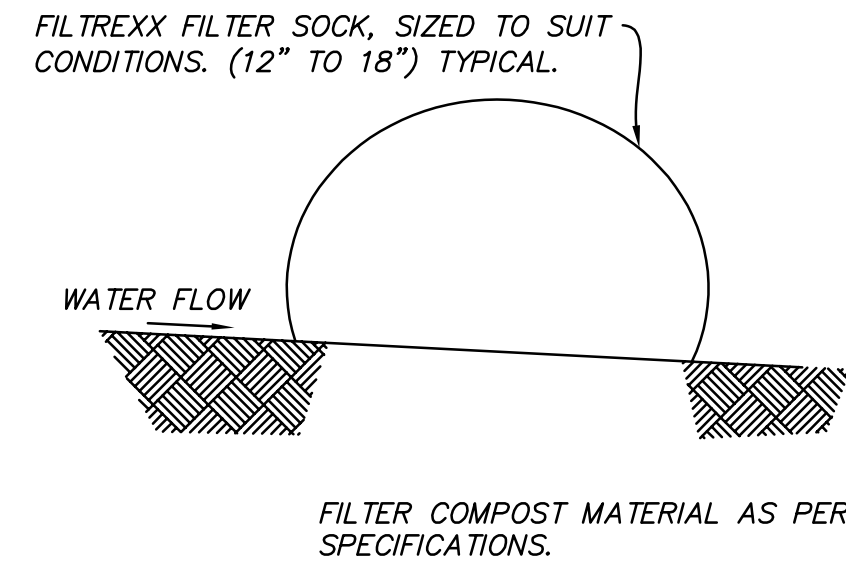

NN VAR FILTREXX SEDIMENT CONTROL DETAIL
NOT TO SCALE

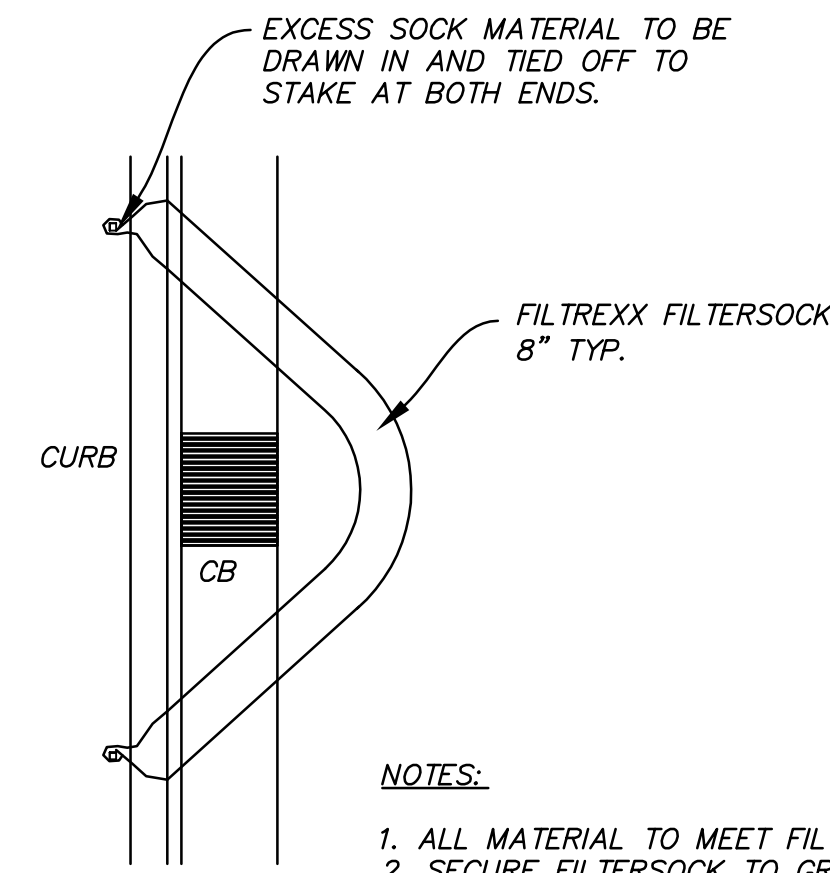

PLAN VIEW

- NOTES:**
1. ALL MATERIAL TO MEET FILTREXX SPECIFICATIONS.
 2. SECURE FILTERSOCK TO GROUND AT EACH END.

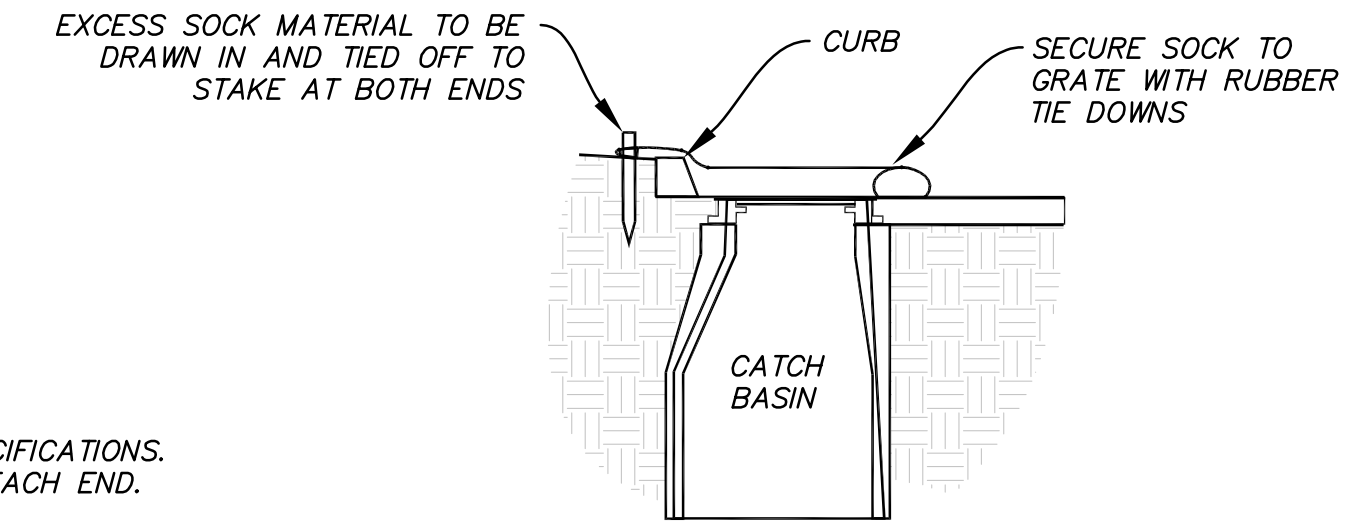

SECTION VIEW

QQ VAR FILTREXX INLET PROTECTION -CURB INLET
NOT TO SCALE

- NOTES:**
1. ALL MATERIAL TO MEET FILTREXX SPECIFICATIONS.
 2. COMPOST MATERIAL WILL BE DISPERSED ON SITE WHEN NO LONGER REQUIRED, AS DETERMINED BY THE ENGINEER.
 3. SPACE SO TOP OF DOWNSTREAM DITCH CHECK IS AT SAME ELEV. AS TOE OF UPSTREAM DITCH CHECK.

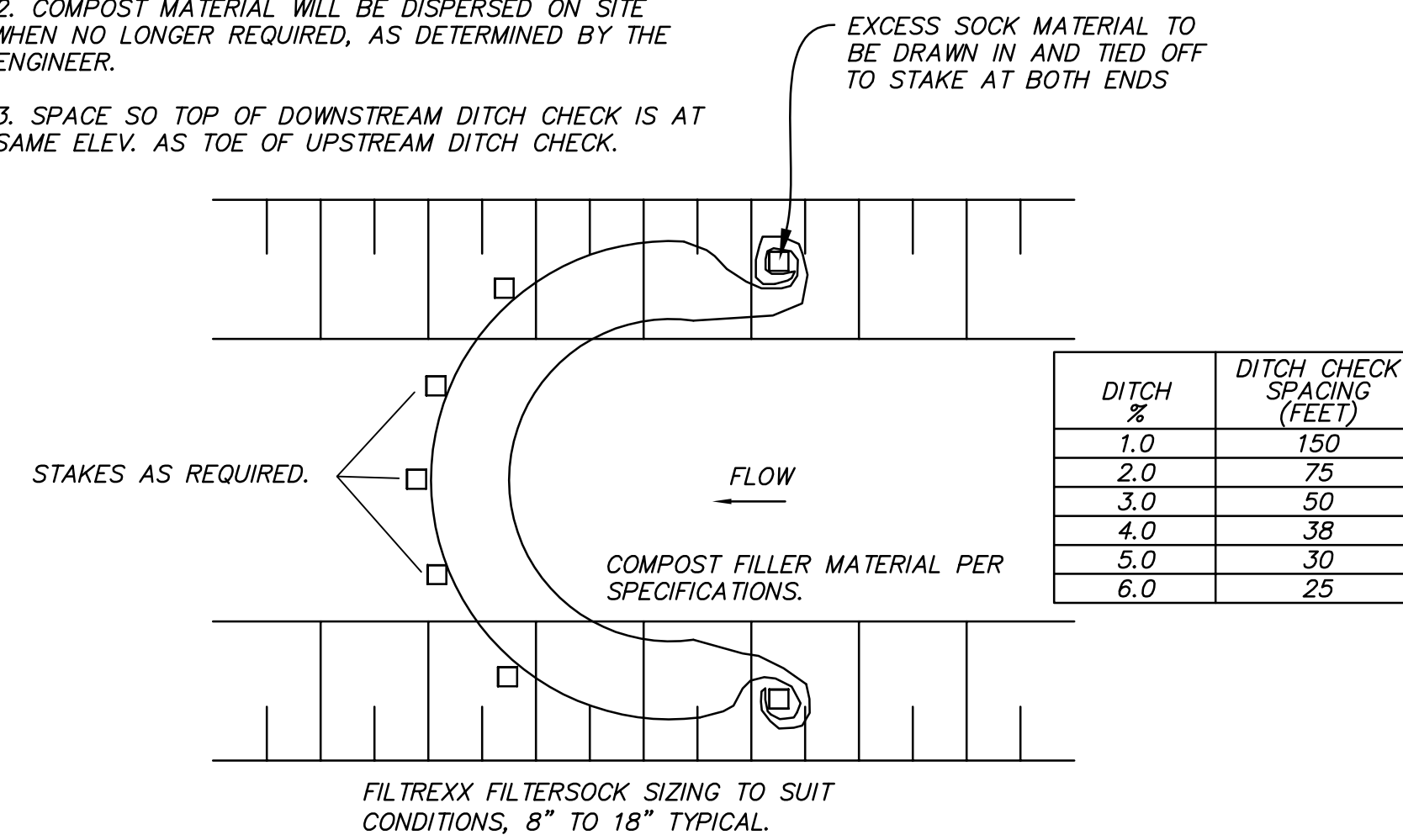

PP VAR TYPICAL FILTREXX DITCH CHECK
NOT TO SCALE

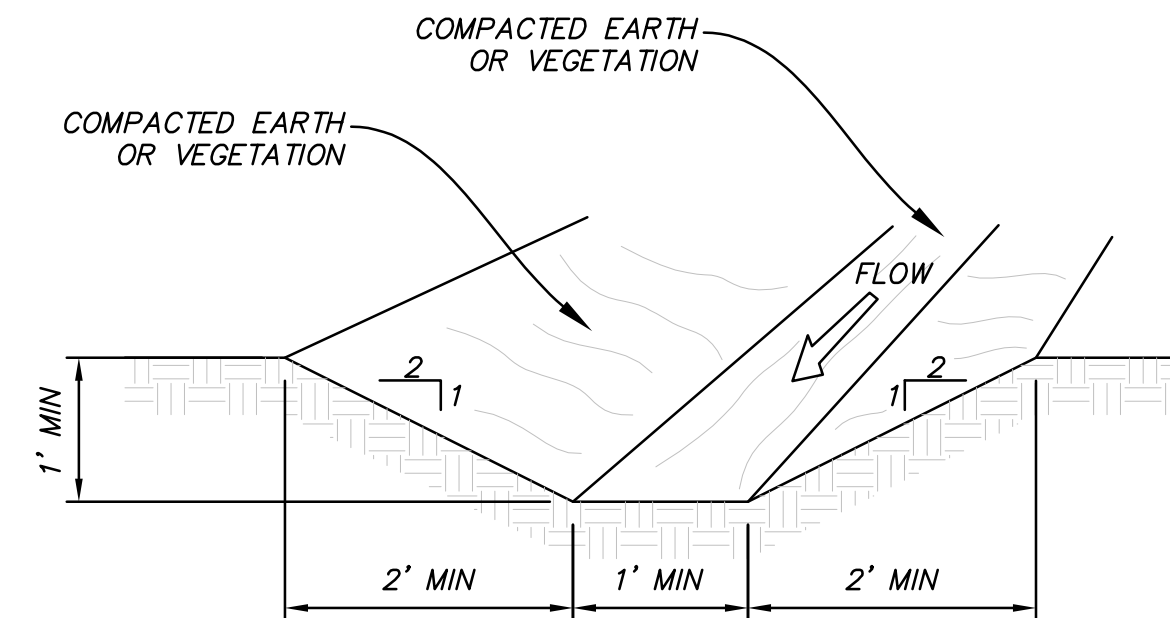

NOTE: INSTALL FILTREXX DITCH CHECKS AS SHOWN ON PLANS PER DETAIL PP/ERO2

OO VAR TEMPORARY INTERCEPTOR DITCH AND FILTREXX DITCH CHECK
NOT TO SCALE

NO.	DATE	DESCRIPTION	MARK	APPR.

DESIGNED BY: JTA	DATE: SEPT. 2015	REV:
DRAWN BY: SKS	SOLUTION NO: XXX	
SUBMITTED BY: N:\00182_Dogbrewh\0008\PA\01\024_DT03	CONTRACT NO: 00387	
FILE NAME: N:\00182_Dogbrewh\0008\PA\01\024_DT03	PLotted BY: N:\00182_Dogbrewh\0008\PA\01\024_DT03	
SIZE: A3	PLotted DATE: 8/10/2015 3:36:39 PM	

DAYBREAK PLAT 101
DETAILS

SHEET NUMBER
24
OF 24 SHEETS
DRAWING NAME
DT03

